

G6-M4-Lesson 1: The Relationship of Addition and Subtraction

1. Fill in each blank.

a. _____ + 25 - 25 = 45
45

I know that when I begin with a number, add another number, and then subtract the added number, I return to the original number. Since the result is 45, the original number must be 45.

b. 375 - 250 + 250 = _____
375

c. 1,450 - _____ + 450 = 1,450
450

I know that when I begin with a number, subtract another number, and then add the subtracted number, I return to the original number.

2. Why are the equations $x + y - y = x$ and $x - y + y = x$ called identities?

These equations are called identities because the variables can be replaced with any number, and after completing the operations, the result is the original number.

I can test this by replacing the variables with numbers. If I replace x with 10 and y with 4, the resulting number sentence $10 + 4 - 4 = 10$ is true. The other resulting number sentence $10 - 4 + 4 = 10$ is also true.

G6-M4-Lesson 2: The Relationship of Multiplication and Division

1. Fill in each blank to make each equation true.

a. $145 \div 5 \times 5 = \underline{\hspace{2cm}}$

145

b. $\underline{\hspace{2cm}} \div 15 \times 15 = 480$

480

c. $65 \times \underline{\hspace{2cm}} \div 15 = 65$

15

d. $533 \times 13 \div \underline{\hspace{2cm}} = 533$

13

If I divide a number by another number and then multiply that result by the number I divided by, my final result is the original number.

If I multiply a number by another number and then divide that result by the number I multiplied by, my final result is the original number.

2. How is the relationship of multiplication and division similar to the relationship of addition and subtraction?

Both relationships create identities.

I can prove this by substituting the variables in the identities with numbers. In the identity $x + y - y = x$, I can replace x with 8 and y with 4. $8 + 4 - 4 = 8$. This is a true equation. This is also true for the relationship between multiplication and division. Using the same replacements in the identity $x \times y \div y = x$, the result is $8 \times 4 \div 4 = 8$, which is a true equation.

G6-M4-Lesson 3: The Relationship of Multiplication and Addition

Write an equivalent expression to show the relationship between multiplication and addition.

1. $20 + 20 + 20$
 3×20

20 is repeatedly added 3 times.
This is the same as 3×20 .

2. 7×3

$3 + 3 + 3 + 3 + 3 + 3 + 3$

There are 7 copies of 3.
I can repeatedly add 3 seven times.

3. $8x$

$x + x + x + x + x + x + x + x$

There are 8 copies of x .
I can repeatedly add x eight times.

4. $f + f + f + f$
 $4f$



f is repeatedly added 4 times.
This is the same as $4 \times f$, or $4f$.

G6-M4-Lesson 4: The Relationship of Division and Subtraction

Build subtraction equations using the indicated equations.

The quotient in each of these equations represents the number of groups.

The number of groups is represented in the tape diagrams, as well.

	Division Equation	Divisor Indicates the Size of the Unit	Tape Diagram	What is x or y ?
1.	$10 \div x = 2$	$10 - x - x = 0$		$x = 5$
2.	$24 \div x = 3$	$24 - x - x - x = 0$		$x = 8$
3.	$35 \div y = 5$	$35 - y - y - y - y - y = 0$		$y = 7$

The quotient is also represented by the number of times the divisor is repeatedly subtracted from the dividend. The number that is being repeatedly subtracted is the dividend.

The divisor is the number in each of the groups.

The quotient in each of these equations represents the number that is repeatedly subtracted from the dividend.

The number that is repeatedly being subtracted (the quotient) is represented in the tape diagrams, as well.

	Division Equation	Divisor Indicates the Number of Units	Tape Diagram	What is x or y ?
1.	$10 \div x = 2$	$10 - 2 - 2 - 2 - 2 = 0$		$x = 5$
2.	$24 \div x = 3$	$24 - 3 - 3 - 3 - 3 - 3 - 3 - 3 = 0$		$x = 8$
3.	$35 \div y = 5$	$35 - 5 - 5 - 5 - 5 - 5 = 0$		$y = 7$

The quotient is being repeatedly subtracted from the dividend. The total number of times it was subtracted is the divisor.

The divisor is the number of times, or the number of groups of, the quotient that was repeatedly subtracted from the dividend.

G6-M4-Lesson 5: Exponents

1. Complete the table by filling in the blank cells. Use a calculator when needed.

Exponential Form	Expanded Form	Standard Form
2^3	$2 \times 2 \times 2$	8
5^4	$5 \times 5 \times 5 \times 5$	625
$(1.5)^2$	1.5×1.5	2.25
$\left(\frac{1}{3}\right)^5$	$\frac{1}{3} \times \frac{1}{3} \times \frac{1}{3} \times \frac{1}{3} \times \frac{1}{3}$	$\frac{1}{243}$

When I am given exponential form, I can expand by multiplying the base factor by itself the number of times the exponent states. Then, I can evaluate the multiplication expression. When I am given the expanded form, I note the factor being multiplied as the base and then count the number of times it is being multiplied. That number represents the exponent.

2. Why do whole numbers raised to an exponent get greater, while fractions raised to an exponent get smaller?

As whole numbers are multiplied by themselves, products are larger because there are more groups. As fractions of fractions are taken, the product is smaller. A part of a part is less than how much was started with.

3. The powers of 3 that are in the range 3 through 1,000 are 3, 9, 27, 81, 243, and 729. Find all the powers of 4 that are in the range 4 through 1,000.

4, 16, 64, 256

4. Find all the powers of 5 in the range 5 through 1,000.

5, 25, 125, 625

I begin with the base factor and continue to multiply it by itself repeatedly until I determine the last product before I reach 1,000.

5. Write an equivalent expression for $x \times y$ using only addition.

$$\underbrace{(y + y + \dots + y)}_{x \text{ times}}$$

Because multiplication is repeated addition, I add y to itself the number of times x states.

6. Write an equivalent expression for n^t using only multiplication.

$$\underbrace{(n \cdot n \cdot \dots \cdot n)}_{t \text{ times}}$$

Because a number to a power is repeated multiplication, I multiply the base factor n by itself the number of times t states.

- a. Explain what n is in this new expression.

n is the factor that is repeatedly multiplied by itself.

- b. Explain what t is in this new expression.

t is the number of times n will be multiplied.

7. What is the advantage of using exponential notation?

It is a more efficient way of writing a multiplication expression if the factors are all the same.

8. What is the difference between $5x$ and x^5 ? Evaluate both of these expressions when $x = 3$.

$5x$ means five times x . This is the same as $x + x + x + x + x$. x^5 means x to the fifth power, or $x \cdot x \cdot x \cdot x \cdot x$.

When $x = 3$, $5x = 5 \cdot 3 = 15$.

When $x = 3$, $x^5 = 3 \cdot 3 \cdot 3 \cdot 3 \cdot 3 = 243$.

G6-M4-Lesson 6: The Order of Operations

Evaluate each expression.

1. $2 \times 4 + 1 \times 7 + 1$

$8 + 7 + 1$

16

I know that multiplication is repeated addition and should be evaluated first in this problem. Then I can find the sum of the resulting addition expression.

2. $(\$1.50 + 2 \times \$0.75 + 5 \times \$0.01) \times 20$

$(\$1.50 + \$1.50 + \$0.05) \times 20$

$\$3.05 \times 20$

$\$61$

I need to evaluate the expressions within the parentheses first. The most powerful operation in the parentheses is multiplication. I will multiply first and then have a resulting addition expression within the parentheses. From there I will evaluate the addition expression in the parentheses first and then multiply by 20.

3. $(3 \times 7) + (7 \times 2) + 2$

$21 + 14 + 2$

37

I know sometimes parentheses group parts of an expression for clarity. In this problem, the parentheses are actually not necessary since the operation of multiplication would be evaluated first.

4. $((15 \div 5)^2 - (27 \div 3^2)) \times (6 \div 3)$

$((3)^2 - (27 \div 9)) \times 2$

$(9 - 3) \times 2$

6×2

12

I know that I have to evaluate what is in the parentheses first. But in this problem, exponents are in different places—outside parentheses and inside parentheses. I need to evaluate the exponent inside the parentheses before I can evaluate the expressions inside the parentheses.

G6-M4-Lesson 7: Replacing Letters with Numbers

1. Replace the side length of this square with 7 in., and find the area.

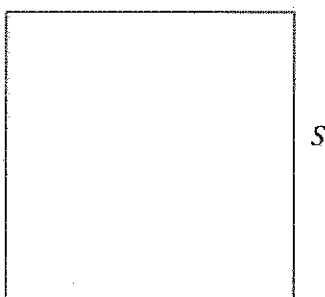

I can substitute the value given for S , 7 in., into the formula for the area of a square.

If the side length of the square is 7 in., the area of the square, S^2 , is $(7 \text{ in.})^2$ or $7 \text{ in.} \times 7 \text{ in.} = 49 \text{ in.}^2$.

2. Complete the table for each of the given figures.

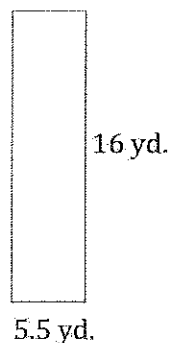
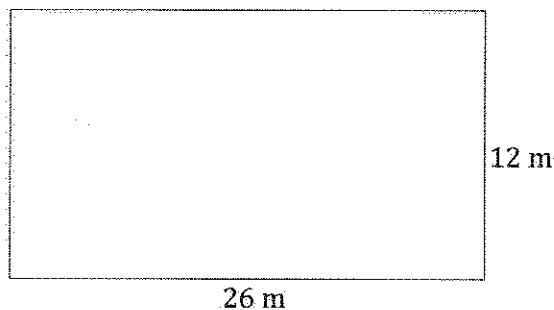

Length of Rectangle	Width of Rectangle	Rectangle's Area Written as an Expression	Rectangle's Area Written as a Number
26 m	12 m	$26 \text{ m} \times 12 \text{ m}$	312 m^2
16 yd.	5.5 yd.	$16 \text{ yd.} \times 5.5 \text{ yd.}$	88 yd^2

3. Find the perimeter of each quadrilateral in Problems 1 and 2.

Problem 1: $P = 28$ in.

Problem 2: $P = 76$ m; $P = 43$ yd.

I can use the formula for perimeter $(l + w + l + w)$, substitute the values for the length and width of each rectangle, and then add.

4. Using the formula $V = l \times w \times h$, find the volume of a right rectangular prism when the length of the prism is 38 cm, the width is 10 cm, and the height is 6 cm.

$$V = l \times w \times h; V = 38 \text{ cm} \times 10 \text{ cm} \times 6 \text{ cm} = 2,280 \text{ cm}^3$$

Using the formula, I can substitute the values given in the problem for length (l), width (w), and height (h). When I multiply the numbers, I can use the commutative property to rearrange the order of the numbers, multiply 38×6 , and then multiply the result by 10.

G6-M4-Lesson 8: Replacing Numbers with Letters

1. Demonstrate the property listed in the first column by filling in the third column of the table.

	Commutative Property of Addition	$37 + c =$	$c + 37$	$a + b = b + a$
$a \times b = b \times a$	Commutative Property of Multiplication	$m \times n =$	$n \times m$	
	Additive Property of Zero	$p + 0 =$	p	$b + 0 = b$
	Multiplicative Identity Property of One	$t \times 1 =$	t	$b \times 1 = b$

2. Why is there no commutative property for subtraction or division? Show examples.

Here is an example of why the commutative property does not work for division. $12 \div 4$ and $4 \div 12$. $12 \div 4 = 3$, but $4 \div 12 = \frac{1}{3}$. For subtraction, the order is important because it can result in different answers. $9 - 2 = 7$, but $2 - 9 = -7$.

G6-M4-Lesson 9: Writing Addition and Subtraction Expressions

1. Write two expressions to show a number increased by 6. Then, draw models to prove that both expressions represent the same thing.

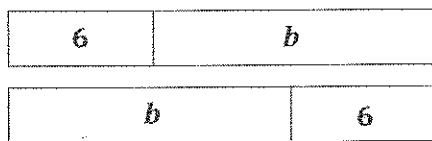

$b + 6$ and $6 + b$

“Increased” tells me I am adding a quantity to another number. For any value of b , each expression would result in the same number.

2. Write an expression to show the sum of a and b .

$a + b$ or $b + a$

“Sum” implies addition.

3. Write an expression to show y decreased by 9.

$y - 9$

Because the order is important when subtracting, “decreased by” tells us the starting amount and the number that is being taken away.

4. Write an expression to show z less than 11.25.

$11.25 - z$

“Less than” also implies subtraction.

5. Write an expression to show the sum of r and m reduced by 21.

$r + m - 21$

Writing this expression requires two steps. First, r and m are being added. Then, the sum is the starting amount in a subtraction problem.

6. Write an expression to show 4 less than l , plus e .

$$l - 4 + e$$

First, l is the starting amount, and 4 is being taken away. Then, the difference is added to e .

7. Write an expression to show 3 less than the sum of p and n .

$$p + n - 3$$

First, p and n are added together. Then, the sum is the starting amount in a subtraction problem.

G6-M4-Lesson 10: Writing and Expanding Multiplication Expressions

1. Rewrite the expression in standard form. Use the fewest number of symbols and characters possible.

a. $6 \cdot 3 \cdot a \cdot b$

$18ab$

b. $4 \cdot 5 \cdot 2 \cdot 10 \cdot y$

$400y$

When I write an expression in standard form, I do not use the operation symbol or symbols for multiplication. I write the factors next to each other. When possible, I multiply numbers together before writing the product next to the variable or variables.

2. Write the following expressions in expanded form.

a. $26yz$

$26 \cdot y \cdot z$ or $2 \cdot 13 \cdot y \cdot z$

b. $12xyz$

$12 \cdot x \cdot y \cdot z$ or $2 \cdot 2 \cdot 3 \cdot x \cdot y \cdot z$

When I write an expression in expanded form, I write the expression as a product of the factors using the “ \cdot ” symbol for multiplication.

3. Find the product.

a. $9a \cdot 3b$

$27ab$

I multiply the coefficients and then write the rest of the variables in alphabetical order.

b. $6ab \cdot 11cd$

$66abcd$

G6-M4-Lesson 11: Factoring Expressions

1. Use models to prove that $4(x + y)$ is equivalent to $4x + 4y$.

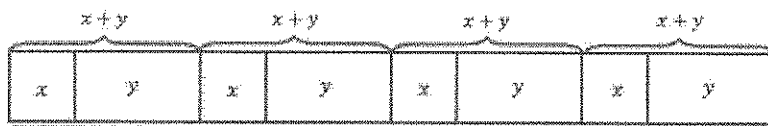

There are four groups of $(x + y)$. The model represents $(x + y) + (x + y) + (x + y) + (x + y)$, or $4(x + y)$.

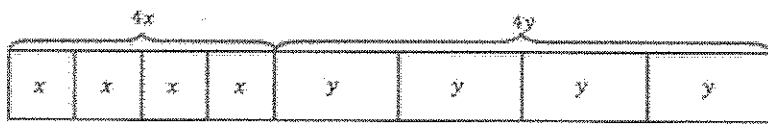

Each model includes four x 's and four y 's, so they are equivalent. Therefore, $4(x + y) = 4x + 4y$.

The model represents x plus x plus x plus x plus y plus y plus y plus y , or four x 's plus four y 's. This can also be expressed as four times x plus four times y .

2. Use greatest common factor and the distributive property to write equivalent expressions in factored form for the following expressions.

a. $4d + 12e$

$4(d + 3e)$ or $4(1d + 3e)$

b. $18x + 30y$

$6(3x + 5y)$

The greatest common factor of $4d + 12e$ is 4, so I can write 4 outside of the parentheses.

I can rewrite the expression as an equivalent expression in factored form, which means the expression is written as the product of factors. The number outside of the parentheses is the greatest common factor, or GCF.

G6-M4-Lesson 12: Distributing Expressions

1. Use the distributive property to write the following expressions in standard form.

a. $9(x + y)$
 $9x + 9y$

I can visualize the model, which would show nine groups of $(x + y)$, which can also be represented as $9x$ and $9y$.

b. $5(2a + b)$
 $10a + 5b$

I can also multiply the number outside the parenthesis by the terms inside the parentheses: $a(b + c) = ab + ac$.
So I can multiply $5 \times 2a$ and $5 \times b$. This would result in the expression $10a + 5b$.

c. $2(7g + 12h)$
 $14g + 24h$

2. Create a model to show that $3(2x + 3y) = 6x + 9y$.

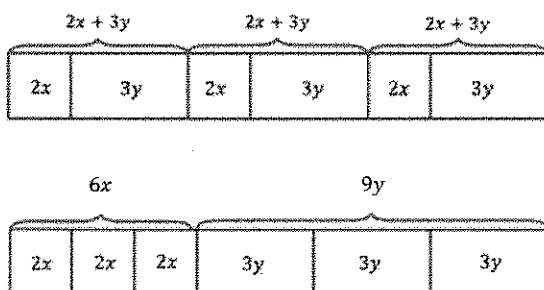

In the first model, there are three groups of $(2x + 3y)$. In the second model, there are three groups of $2x$, or $6x$ altogether, and three groups of $3y$, or a total of $9y$. In both models, there are three $2x$ terms and three $3y$ terms. They are just grouped differently.

G6-M4-Lesson 13: Writing Division Expressions

1. Rewrite the expressions using the division symbol and as a fraction.

- a. Eighteen divided by 23

$$18 \div 23 \text{ and } \frac{18}{23}$$

Writing a fraction to show division is more efficient than drawing models, arrays, or using the division symbol.

- b. The quotient of n and 9

$$n \div 9 \text{ and } \frac{n}{9}$$

- c. 8 divided by the sum of y and 5

$$8 \div (y + 5) \text{ and } \frac{8}{y + 5}$$

When using the division symbol, I can show the sum of y and 5 by placing them in parentheses. I do not always need the parentheses in the denominator when writing the expression as a fraction.

2. Draw a model to show that $x \div 4$ is the same as $\frac{x}{4}$.

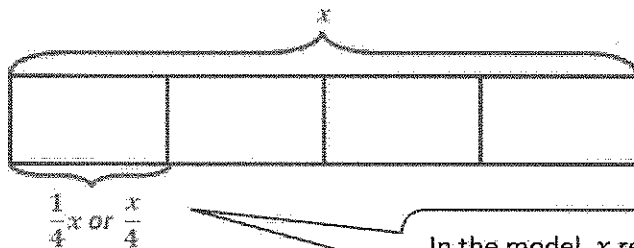

In the model, x represents the whole. If x is divided into 4 parts, one of the parts represents $\frac{1}{4}x$, or $\frac{x}{4}$.

G6-M4-Lesson 14: Writing Division Expressions

Complete the missing spaces in each rectangle set.

Since x is being divided by the sum of y and 12, it is the dividend. The divisor is $y + 12$ because it is what I am dividing by.

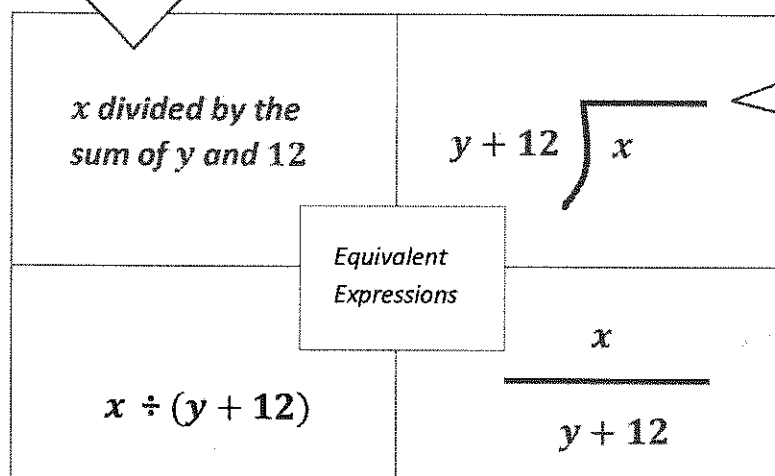

Here, the dividend, x , is inside the division symbol because it is what is being divided. The divisor, $y + 12$, is outside the symbol because it is what I am dividing by.

Division can be represented as a fraction. The numerator represents the dividend, x . The denominator represents the divisor, $y + 12$.

G6-M4-Lesson 15: Read Expressions in Which Letters Stand for Numbers

1. List five different vocabulary words that could be used to describe the given expression.

$$\frac{4m - 6}{k}$$

I know from Lesson 13 that a fraction is another way to show division.

To determine what vocabulary words to use, I need to identify which operations are being shown and then brainstorm different ways to describe those operations.

Possible Answers: Difference, less than, quotient, product, quadruple

2. Write an expression using math vocabulary for each expression below.

a. $7 - 5h$

I need to show that 5 is being multiplied by h before it is subtracted from 7.

Possible Answers: The product of 5 and h subtracted from 7; seven minus the quantity 5 times h

b. $\frac{m+2}{4}$

I need to show that the entire numerator is being divided by 4. I can group m and 2 together using words like "the quantity."

Possible Answers: The quantity m plus 2 divided by 4; the quotient of m plus 2 and 4

G6-M4-Lesson 16: Write Expressions in Which Letters Stand for Numbers

Mark the text by underlining key words, and then write an expression using variables and numbers for each of the statements below.

1. The difference of g and 18 is divided by h squared.

The difference of g and 18 is divided by h squared.

I need to determine the operations that the key words are describing. *Difference* is the result of subtraction.

$$\frac{g - 18}{h^2}$$

I can write " h squared" as h to the second power.

2. Noelle read p pages yesterday. Marcus read 9 pages more than one-third of the pages Noelle read. Write an expression that represents the number of pages that Marcus read.

Noelle read p pages yesterday. Marcus read 9 pages more than one-third of the pages Noelle read. Write an expression that represents the number of pages that Marcus read.

$$\frac{1}{3}p + 9 \text{ or } \frac{p}{3} + 9 \text{ or } p \div 3 + 9$$

To determine the number of pages Marcus read, I need to represent one-third of the pages Noelle read before I can add 9 to that amount.

One-third of describes multiplication. Because $\frac{1}{3}$ is a fraction, it also describes division.

G6-M4-Lesson 17: Write Expressions in Which Letters Stand for Numbers

Write an expression using letters and/or numbers for each problem below.

1. 13 times the difference of k and 7

$$13(k - 7)$$

I can use parentheses to show that 13 is being multiplied by the difference of k and 7 instead of just being multiplied by k .

2. The quantity of h increased by 14 divided by three times m

$$\frac{h + 14}{3m}$$

I can show the quotient using a fraction. The first quantity will be the numerator because that is the dividend (what is being divided), and the second quantity, which I am dividing by (or the divisor), will be the denominator.

3. Melinda can do 2 times as many push-ups as Tim and Quinn combined. Tim can do t push-ups, and Quinn can do q push-ups.

$$2(t + q)$$

Tim and Quinn combined means that I need to add together the number of push-ups that each of them can do before multiplying by two.

4. Yesterday, the temperature was 28 degrees warmer than triple the temperature, t , four months ago.

$$3t + 28$$

Warmer tells me I need to add 28 to the product of t and 3.

G6-M4-Lesson 18: Writing and Evaluating Expressions—Addition and Subtraction

1. Read the story problem. Part (a): Identify the unknown quantity, and write the addition or subtraction expression that is described. Part (b): Evaluate your expression using the information given.

- a. The home football team scored 17 more points than the away team.

Description with units: Let p represent the points the away team scored.

Expression: $p + 17$

- b. The away team scored 19 points in the game.

$$p + 17$$

$$19 + 17$$

$$36$$

The home team scored 36 points in the game.

I do not know how many points the away team scored, so I will use a variable. Then I can add 17 to determine the points the home team scored.

2. If the home team had scored 42 points, how would you determine the number of points scored by the away team?

I would subtract 17 points from 42 points to get 25 points for the away team.

This time I was given the points the home team scored instead of the points the away team scored. So I need to do the opposite of adding.

G6-M4-Lesson 19: Substituting to Evaluate Addition and Subtraction Expressions

1. Makenzie and Micah went to Caspersen Beach, Florida, to collect shark teeth. Before they went, Makenzie had 13 teeth in her collection, and Micah had 4 teeth in his collection. On an 8-day trip, they each collected 3 new teeth each day.
- a. Make a table showing how many teeth each person had in his or her collection at the end of each day.

Day	Number of Shark Teeth in Makenzie's Collection	Number of Shark Teeth in Micah's Collection
1	16	7
2	19	10
3	22	13
4	25	16
5	28	19
6	31	22
7	34	25
8	37	28

On the first day, I need to add 3 to the totals for each person. And each day after that I will add 3 more to represent the new shark teeth they found.

My table needs a row for each of the 8 days in the trip. It also needs a column for each person.

- b. If this pattern of shark teeth finding continues, how many teeth does Micah have when Makenzie has T shark teeth?

I can see that Micah has fewer shark teeth. So I know I will be subtracting some amount from the number that Makenzie has.

When Makenzie has T shark teeth, Micah has $T - 9$ shark teeth.

- c. If this pattern of shark teeth finding continues, how many shark teeth does Micah have when Makenzie has 70 shark teeth?

$$70 - 9 = 61$$

I need to use the expression I came up with in part (b) to help me answer the question.

When Makenzie has 70 shark teeth, Micah has 61 shark teeth.

- d. If this pattern of shark teeth finding continues, how many teeth does Makenzie have when Micah has M shark teeth?

When Micah has M shark teeth, Makenzie has $M + 9$ shark teeth.

I already know that the number of teeth is always 9 apart, but this time I need to add 9 because Makenzie has 9 more than Micah every day.

2. Maya and Albert are making necklaces that consist of large round beads and small square beads. The relationship between the number of large round beads and the total number of beads is shown in the table.

Number of Large Round Beads	Total Number of Beads
0	6
1	7
2	8
5	11
50	56

In this problem, I am given a completed table. I need to see what number was added to the number of large round beads to determine the total number of beads.

- a. Maya wrote an expression for the relationship depicted in the table as $R + 6$. Albert wrote an expression for the same relationship as $T - 6$. Is it possible to have two different expressions to represent one relationship? Explain.

Both expressions can represent the same relationship, depending on the point of view. The expression $R + 6$ represents the number of large round beads plus the number of small square beads. The expression $T - 6$ represents the number of small square beads taken away from the total number of beads.

- b. What do you think the variable in each student's expression represents? How would you define them?

The variable T would represent the total number of beads on the necklace. The variable R would represent the number of large round beads.

- c. If the same pattern continues, how many large beads will be on the necklace if there are 72 beads total?

$$T - 6$$

$$72 - 6$$

$$66$$

Because I am given the total number of beads, it makes sense to use the expression $T - 6$ to solve for the number of large round beads.

There would be 66 large round beads used if there are 72 total beads.

G6-M4-Lesson 20: Writing and Evaluating Expressions— Multiplication and Division

1. A seamstress can sew 180 skirts per month.
- a. Write an expression describing how many skirts are made by the seamstress in M months.

$$180M$$

I can replace the variable with a number to help me think through the problem. If the seamstress sewed for 2 months, she would make 180×2 skirts. And in 3 months, she would make 180×3 skirts. So in M months she must make $180 \times M$ skirts.

- b. How many skirts will be in an entire year (12 months)?

$$180 \cdot 12 = 2,160. \text{ There will be 2,160 skirts made in a year.}$$

- c. How long does it take the seamstress to complete 1,980 skirts?

$$1,980 \text{ skirts} \div 180 \frac{\text{skirts}}{\text{month}} = 11 \text{ months}$$

To get the total number of skirts, I multiplied. So to get the number of months, I will do the opposite, or inverse.

2. Malik is a hot dog vendor, for which he earns \$2.30 per hot dog sold. Create a table of values that shows the relationship between the number of hot dogs that Malik sells, H , and the amount of money Malik earns in dollars, D .

I can choose any numbers for the number of hot dogs, like 1, 2, 3, 4, or 10, 20, 30, 40, and then use them to determine the total earnings.

Number of Hot Dogs Sold (H)	Malik's Earnings in Dollars (D)
1	2.30
10	23.00
100	230.00
1,000	2,300.00

- a. If you know how many hot dogs Malik sold, can you determine how much money he earned? Write the corresponding expression.

Multiplying the number of hot dogs that Malik sold by his profit rate (\$2.30 per hot dog) will calculate his money earned. $2.30H$ is the expression for his earnings in dollars.

- b. Use your expression to determine how much Malik earned by selling 90 hot dogs.

$2.30H = 2.30 \cdot 90 = 207$. *Malik earned \$207.00 for selling 90 hot dogs.*

I am given the number of hot dogs, which I can use to replace H in the expression from part (a), and multiply.

- c. Malik must earn \$1,334 each week to cover all of his expenses. Determine how many hot dogs Malik must sell in order to earn \$1,334 in a week.

$1,334 \div 2.30 = 580$. *Therefore, Malik must sell 580 hot dogs each week in order to cover his expenses.*

I am given D , the amount of money in dollars. So I will need to use the opposite operation to solve for H , the number of hot dogs.

G6-M4-Lesson 21: Writing and Evaluating Expressions— Multiplication and Addition

1. Victoria is purchasing shirts at \$8 each for the math team. The company charges \$7.25 for shipping and handling, no matter how many shirts are purchased.
- a. Create a table of values that shows the relationship between the number of shirts that Victoria buys, S , and the amount of money Victoria spends, T , in dollars.

Like in Lesson 20, I can choose the number of shirts that I use in the table.

<i>Number of Shirts Victoria Buys (S)</i>	<i>Total Cost in Dollars (T)</i>
1	15.25
2	23.25
3	31.25

- b. If you know how many shirts Victoria orders, can you determine how much money she spends? Write the corresponding expression.

$$8S + 7.25$$

First, I can determine the cost of the shirts, and then I will add on the shipping cost.

- c. Use your expression to determine how much Victoria spent buying 30 shirts.

$$8(30) + 7.25$$

$$247.25$$

Victoria spent \$247.25.

Now I can use the expression I came up with in part (b) to solve when $S = 30$.

2. When riding in a taxi, Hector pays a \$3 flat fee and \$2.75 per mile. The relationship between the number of miles, M , and the total cost, C , is shown in the table.
- a. Complete the missing values in the table.

Number of Miles (M)	Total Cost in Dollars (C)
1	5.75
2	8.50
3	11.25
4	14
5	16.75
6	19.50

I can see a pattern in the second column. The cost is increasing by \$2.75 each time another mile is added in the first column.

- b. Write an expression that shows the cost of taking the taxi for a total of M miles.

$$3 + 2.75M$$

I add the flat fee to the cost for the miles traveled.

- c. If Hector can only spend \$47 on the taxi ride, how many miles can he travel?

I can work backwards to figure out how many miles Hector can afford. First, I will subtract the flat fee from the total. Then, I will divide by the price per mile.

$$47 - 3 = 44$$

$$44 \div 2.75 = 16$$

Hector can go 16 miles in the taxi.

G6-M4-Lesson 22: Writing and Evaluating Expressions—

Exponents

1. Miguel tried a new restaurant on Day 1. On Day 2, he told 3 friends about the restaurant. On Day 3, each friend told 3 friends about the restaurant, and the pattern continued tripling each day for 9 days.
- a. Complete the table to show how many people heard about the restaurant each day. Write your answers in exponential form on the table below.

Because the number of people is tripling every time, I can use an exponent to represent the amount of people that hear about the restaurant each day.

Day	Number of People	Day	Number of People	Day	Number of People
1	3^0	4	3^3	7	3^6
2	3^1	5	3^4	8	3^7
3	3^2	6	3^5	9	3^8

- b. How many people would be told about the restaurant on Day 9? Represent your answer in exponential form and standard form. Use the table above to help solve the problem.

To find out how many people will hear about the restaurant on Day 9, I need to solve $3 \times 3 \times 3 \times 3 \times 3 \times 3 \times 3 \times 3$.

On Day 9, 3^8 —or 6,561—people would hear about the restaurant.

- c. Miguel is estimating that by Day 9 at least 10,000 people will have heard about the restaurant. Is his estimate accurate? Why or why not?

At least 10,000 means 10,000 or more.

$$1 + 3 + 9 + 27 + 81 + 243 + 729 + 2187 + 6561 = 9841$$

By Day 9, only 9,841 people will have heard about the restaurant. Although 9,841 is close to 10,000, it is not over 10,000. Miguel estimated that at least 10,000 would have heard about the restaurant, which would mean 10,000 or more.

To find out how many total people have heard about the restaurant, I need to add the totals from each day.

2. If an amount of money is invested at an annual interest rate of 9%, it doubles every 8 years. If Van invests \$700, how long will it take for his investment to reach \$2,800 (assuming he does not contribute any additional funds)?

It will take 16 years to reach \$2,800.

After 8 years, it will reach \$1,400. Then after another 8 years, it will double again to \$2,800.

G6-M4-Lesson 23: True and False Number Sentences

Substitute the value for the variable, and state whether the resulting number sentence is true or false. If true, find a value that would result in a false number sentence. If false, find a value that would result in a true number sentence.

1. $4\frac{1}{2} = 2\frac{3}{4} + g$. Substitute $1\frac{3}{4}$ for g .

$$4\frac{1}{2} = 2\frac{3}{4} + g$$

First, I need to replace g with $1\frac{3}{4}$.

$$4\frac{1}{2} = 2\frac{3}{4} + 1\frac{3}{4}$$

Next, I need to find the sum of $2\frac{3}{4}$ and $1\frac{3}{4}$.

$$4\frac{1}{2} = 4\frac{1}{2}$$

Then, I need to determine if the sum, $4\frac{1}{2}$, creates a true number sentence.

This is a true number sentence because $4\frac{1}{2}$ is equal to $4\frac{1}{2}$. Any number other than $4\frac{1}{2}$ will result in a false number sentence.

2. $\frac{b}{4} = 12$. Substitute 60 for b .

$$\frac{b}{4} = 12$$

First, I need to replace b with 60.

$$\frac{60}{4} = 12$$

Next, I need to find the quotient of 60 and 4.

$$15 = 12$$

Then, I need to determine if the quotient, 15, creates a true number sentence.

This is a false number sentence because when 60 is divided by 4, the quotient is 15. In order for this to be a true number sentence, the quotient must equal 12. To create a true number sentence, the variable, b , must be replaced with a number that, when divided by 4, will create a quotient of 12. When replacing b , the only number that will create a true number sentence is 48.

Create a number sentence using the given variable and symbol. The number sentence you write must be true for the given value of the variable.

3. Variable: m Symbol: \geq The sentence is true when 13 is substituted for m .

$$m \geq$$

I know that m is the variable and that I will be using the greater than or equal to sign.

When I substitute 13 for m , I know that whatever is on the right side of the \geq sign must be equal to 13 or be less than 13.

$$13 \geq$$

$$13 \geq 12 - 7$$

$$13 \geq \frac{20}{4}$$

$$13 \geq 2 + 11$$

$$13 \geq 13$$

$$13 \geq 7$$

I know this is a true number sentence because when both sides are evaluated, the resulting number sentence is $13 \geq 5$. Five is less than thirteen, so it is a true number sentence.

I can choose any operations or numbers as long as what I choose results in a true number sentence. These are some other examples of true number sentences.

G6-M4-Lesson 24: True and False Number Sentences

State when the following equations or inequalities will be true and when they will be false.

1. $72 = 2f$

First, I need to determine which number is being represented by f .

$$72 = 2f$$

$$72 = 2(?)$$

$$72 = 2(36)$$

$$72 = 72$$

What number, when doubled, will be equal to 72?

I need to determine if the product of 2 and 36 creates a true number sentence.

The equation $72 = 2f$ is true only when the value of f is 36 and false when the value of f is any number other than 36. The equation is true when $f = 36$ and false when $f \neq 36$.

2. $m - 12 \leq 29$

Any number less than or equal to 29 will result in a true number sentence. I'll start with equal.

$$m - 12 \leq 29$$

$$m - 12 = 29$$

$$41 - 12 = 29$$

$$29 = 29$$

First, I need to think of numbers that are less than or equal to 29.

What number, when I subtract 12 from it, will result in a number equal to 29?

The inequality $m - 12 \leq 29$ is true when the value of m is 41. In this example, when evaluated, $29 = 29$.

What if I choose a number greater than 41? Will that also result in a true number sentence?

$$42 - 12 \leq 29$$

$$30 \leq 29$$

The inequality $m - 12 \leq 29$ is false when the value of m is greater than 41. In this example, 30 is not equal to 29, nor is it less than 29.

What if I choose a number less than 41? Will that also result in a true number sentence?

$$40 - 12 \leq 29$$

$$28 \leq 29$$

The inequality $m - 12 \leq 29$ is true when the value of m is less than 41. In this example, 28 is not equal to 29, but it is less than 29.

Therefore, the inequality $m - 12 \leq 29$ is true when the value of m is less than or equal to 41. It is false when the value of m is more than 41. The inequality is true when $m \leq 41$ and false when $m > 41$.

G6-M4-Lesson 25: Finding Solutions to Make Equations True

Solutions to Equations

When solving equations, there is only one number that the variable can represent that will result in a true number sentence.

Find the solution to each equation.

1. $5^3 = b$

5^3 is evaluated by multiplying the base, 5, by itself the number of times of the exponent, 3. $5 \times 5 \times 5 = 125$.

$$\begin{aligned} 5^3 &= b \\ 125 &= b \\ 125 &= 125 \end{aligned}$$

Each side of the equation must evaluate to the same number.

Since 5^3 is 125, the value of b is the same since they are equal. b must equal 125.

2. $6n = 72$

What number, when multiplied by 6, will result in the product, 72?

$$\begin{aligned} 6n &= 72 \\ 6 \times ? &= 72 \\ 6 \times 12 &= 72 \\ 72 &= 72 \end{aligned}$$

The value of n is 12. It is the only number that can replace n to result in a true number sentence.

The right side of the equation is 72. Because this is an equation, the product of 6 and the number n represents must also equal 72.

3. $\frac{36}{h} = 4$

What number must I divide 36 by in order to have a quotient of 4?

$$\frac{36}{h} = 4$$

$$36 \div ? = 4$$

$$36 \div 9 = 4$$

$$4 = 4$$

The value of h is 9. It is the only number that can replace h to result in a true number sentence.

The right side of the equation is 4. Because this is an equation, the quotient of 36 and the number h represents must also equal 4.

G6-M4-Lesson 26: One-Step Equations—Addition and Subtraction

Find the solution to the equation using tape diagrams.

1. $x - 5 = 15$

This equation is stating that when I subtract 5 from a number (in this case the number is represented by x), then the result is 15. What must that number be that is being represented by x ? There is only one number that can make this equation true. I will start with x .

This tape diagram represents the number that will replace x . It represents the number I am taking 5 from in order to find the difference of 15.

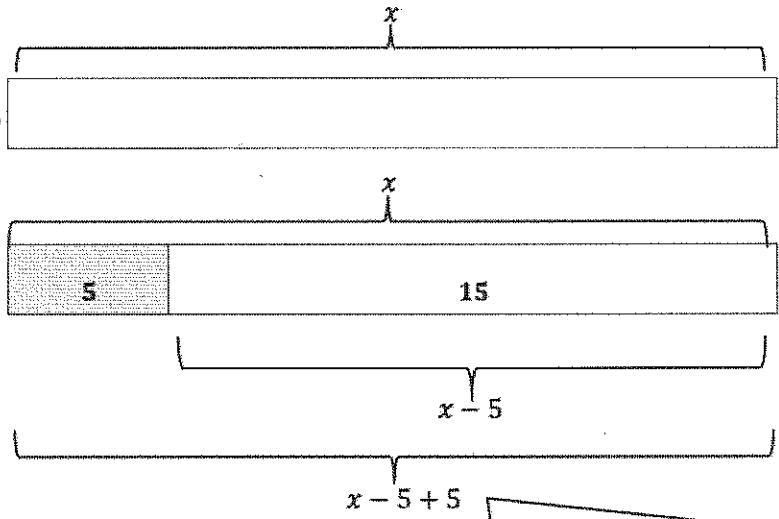

This tape diagram shows that when I take 5 away from the number that is being represented by x , the result is 15.

There are some things I notice here. The remaining 15 is equal to the quantity $x - 5$. This is stated in the problem. When I combine the 5 and the $x - 5$ in the diagram, it is equal to x because $x - 5 + 5 = x$. This is also supported by the knowledge of the properties of operations I learned in Lessons 1–4.

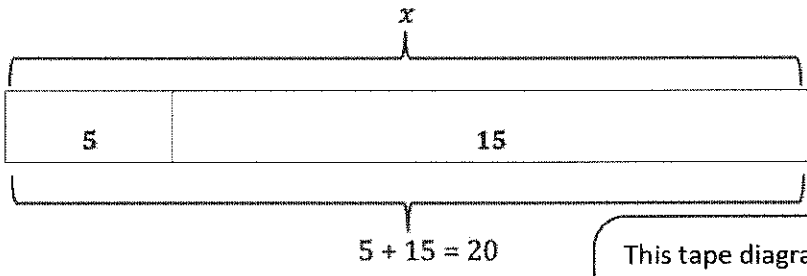

This tape diagram shows that since the tape diagrams are equal, x must be equal to the sum of 5 and 15. Therefore, $x = 20$.

Find the solution to the equation algebraically. Check your answer.

2. $x - 5 = 15$

$$\begin{aligned}x - 5 &= 15 \\x - 5 + 5 &= 15 + 5 \\x &= 15 + 5 \\x &= 20\end{aligned}$$

$x - 5 + 5 = x$. This is supported by the identity that states that if you take a number away from another number, then add it back in, the result is the first number you began with.

Substitution is a common way to check solutions to equations. Substitute the value for x back into the equation, and evaluate to see if a true number sentence results.

$$\begin{aligned}x - 5 &= 15 \\20 - 5 &= 15 \\15 &= 15\end{aligned}$$

This is a true number sentence, so the solution, $x = 20$, is correct.

Many times, students confuse the check with the correct solution since they are often different numbers. In order to avoid this problem, students are encouraged to substitute the solution back into the identity, where they will find that the solution and the check will be the same number, resulting in less confusion.

$$\begin{aligned}x - 5 &= 15 \\x - 5 + 5 &= 15 + 5 \\20 - 5 + 5 &= 15 + 5 \\20 &= 20\end{aligned}$$

This method also results in a true number sentence and shows that x must equal 20 in order for the equation to be true.

Find the solution to the equation algebraically. Check your answer.

4. $y + 7 = 17$

$$\begin{aligned} y + 7 &= 17 \\ y + 7 - 7 &= 17 - 7 \\ y &= 17 - 7 \\ y &= 10 \end{aligned}$$

To check work, substitute y with the solution 10 back into the identity to see if it results in a true number sentence.

$$\begin{aligned} y + 7 &= 17 \\ 10 + 7 &= 17 \\ 10 + 7 - 7 &= 17 - 7 \\ 10 &= 10 \end{aligned}$$

Because the identity $w + x - x = w$, I know that I can subtract 7 from $y + 7$ to determine what y represents. Because $y + 7$ and 17 are equal, I also need to subtract 7 from 17.

This is a true number sentence, so the solution, $y = 10$, is correct.

Identify the mistake in the problem below. Then, correct the mistake.

5. $r + 12 = 32$

$$\begin{aligned} r + 12 &= 32 \\ r + 12 - 12 &= 32 + 12 \\ r &= 44 \end{aligned}$$

The mistake here is adding 12 on the right side of the equation instead of subtracting 12.

The correct answer should be:

$$\begin{aligned} r + 12 &= 32 \\ r + 12 - 12 &= 32 - 12 \\ r &= 20 \end{aligned}$$

G6-M4-Lesson 27: One-Step Equations—Multiplication and Division

Find the solution to the equation using tape diagrams.

1. $24 = 6x$

This equation is stating that when I multiply a number (in this case it is represented by x) and 6, the product is 24. What must that number be that is being represented by x ? There is only one number that can make this equation true. I'm going to start with 24.

These are equal.

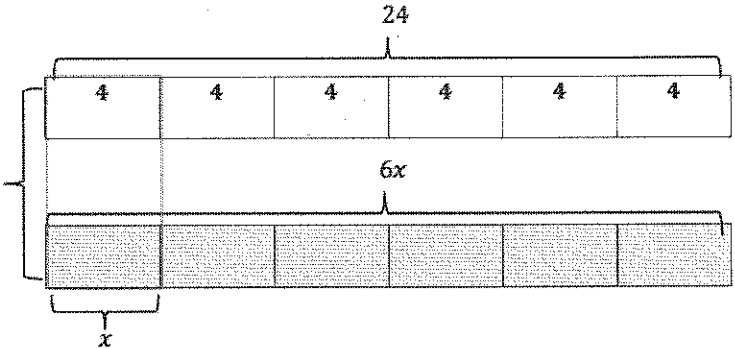

If 24 were to be split into 6 equal groups, as $6x$ has been, what is the value of each of the six groups?

When I split 24 items into 6 groups, each group contains 4 items.
When I split $6x$ into 6 groups, each group contains one x .

Because the identity $w \cdot x \div x = w$, I know that I can divide $6x$ by 6 to determine the value of one x . Since I divided $6x$ by 6, I must also divide 24 by 6 because $6x$ is equal to 24.

Find the solution to the equation algebraically. Check your answer.

2. $24 = 6x$

$$24 = 6x$$

$$24 \div 6 = 6x \div 6$$

$$4 = x$$

Substitute the solution back into the equation, and determine if the result is a true number sentence.

$$24 = 6x$$

$$24 = 6 \cdot 4$$

$$24 \div 6 = 6 \cdot 4 \div 6$$

$$4 = 4$$

This results in a true number sentence and shows that x must equal 4 in order for the equation to be true.

Find the solution to the equation using tape diagrams.

3. $\frac{y}{3} = 21$

This equation is stating that when I divide a number (in this case it is represented by y) and 3, the quotient is 21. What must that number be that is being represented by y ? There is only one number that can make this equation true. I'm going to start with $y \div 3$.

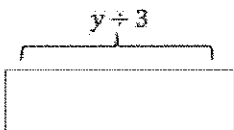

I need three pieces of $y \div 3$ to create one y because $y \div 3 \cdot 3 = y$.

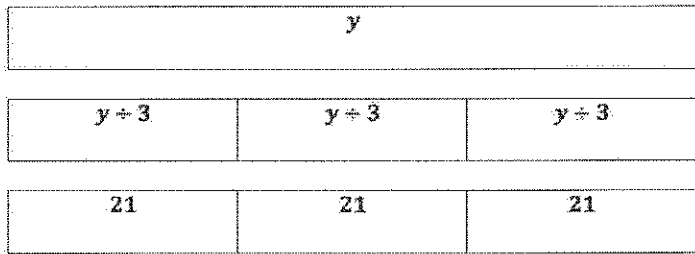

I know that each unit of $y \div 3$ is equal to 21.

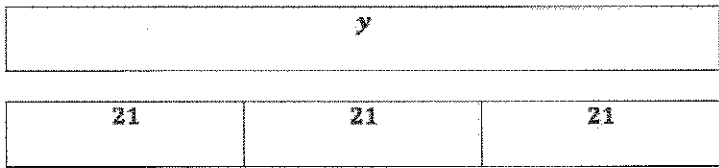

y is equal to $3 \cdot 21$, or $y = 63$.

Find the solution to the equation algebraically. Check your answer.

4. $\frac{y}{3} = 21$

$$\frac{y}{3} = 21$$

$$y \div 3 = 21$$

$$y \div 3 \cdot 3 = 21 \cdot 3$$

$$y = 63$$

$$\frac{y}{3} = 21$$

$$63 \div 3 = 21$$

$$63 \div 3 \cdot 3 = 21 \cdot 3$$

$$63 = 63$$

Because the identity $w \div x \cdot x = w$, I know that I can multiply $\frac{y}{3}$ by 3 to determine the value of one y . Since I multiplied $\frac{y}{3}$ by 3, I must also multiply 21 by 3 because $\frac{y}{3}$ is equal to 21.

G6-M4-Lesson 28: Two-Step Problems—All Operations

Use tape diagrams to solve each problem. Then create a set of equations to solve algebraically.

- Malcolm scored 18 points in tonight's football game, which is 6 points more than his personal best. Jamal scored 2 more points than Alan in tonight's game. Jamal scored the same number of points as Malcolm's personal best. Let m represent the number of points Malcolm scored during his personal best and a represent the number of points Alan scored during tonight's game.
 - How many points did Alan score during the game?

I know Jamal scored 2 more points than Alan, and that equals Malcolm's personal best score of 12. Jamal scored 12 points tonight.

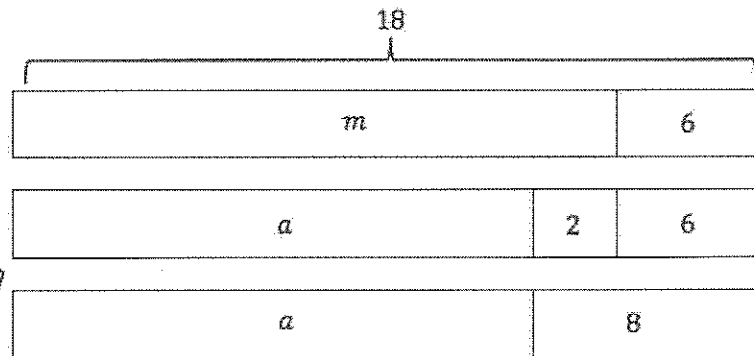

I know that Malcolm's total is 18, part of which is 6. $m + 6 = 18$, so Malcolm's personal best score must be 12.

Equation for Malcolm's Tape Diagram: $m + 6 = 18$

Equation for Jamal's Tape Diagram:

$$a + 2 + 6 = 18$$

$$a + 8 = 18$$

$$a + 8 - 8 = 18 - 8$$

$$a = 10$$

Alan's score, plus the 2 more points Jamal scored, plus the 6 extra points that Malcolm scored over his personal best equals Malcolm's total points from tonight's game, 18.

- What was the total number of points these three boys scored at the end of tonight's game?

Malcolm's points + Jamal's points + Alan's points: $18 + 12 + 10 = 40$. The total number of points the three boys scored at the end of the game was 40.

2. The type of customers at the local bank varies throughout the day. During Saturday's hours, the bank manager collected data to see why the customers were coming into the bank on a Saturday. There were 140 people who made deposits. There were 15 more customers who checked their balances than there were who made withdrawals. The number of customers who made deposits was 5 times as many as those who came in to check their balances. How many customers made withdrawals? How many customers checked their balances? Let w represent the number of customers who made withdrawals, and let b represent the number of customers who only checked their balances.

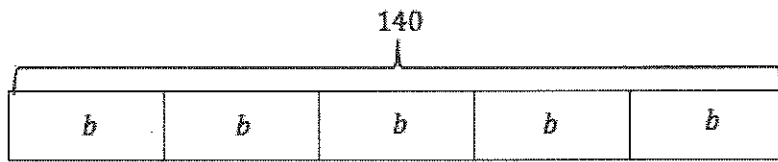

$$5b = 140$$

$$5b \div 5 = 140 \div 5$$

$$b = 28$$

Since there were five times as many customers who made deposits than checked their balances, and I know there were 140 customers who made deposits, $5b = 140$.

Because there were 15 more customers who checked their balances than the number of customers who made withdrawals, I can represent b as $w + 15$.

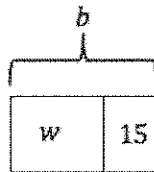

$$w + 15 = b$$

$$w + 15 = 28$$

$$w + 15 - 15 = 28 - 15$$

$$w = 13$$

Now that I know that there were 28 people who checked their balances on Saturday, I can determine how many made withdrawals.

13 customers made withdrawals on Saturday, and 28 customers checked their balances.

G6-M4-Lesson 29: Multi-Step Problems—All Operations

Multistep Problems

Solve the problem using a table, and then check your answer with the word problem.

Camille uses four times as many cups of broth as she does cups of milk in a recipe and double the amount of flour as milk.

- a. If Camille uses 14 cups of these ingredients in the recipe, how many of each does she use?

Begin with 1 cup of milk.

To find out how many cups of flour, double the amount of milk.

Since there are four times as many cups of broth than milk, multiply 1 cup of milk by four.

Number of Cups of Milk	Number of Cups of Flour	Number of Cups of Broth	Total Number of Cups Used
1	2	4	7
2	4	8	14

If she uses 14 cups of ingredients, that is twice as many as the original total of 7 cups. If we double 7 cups, we need to double the rest of the original number of cups.

Camille would use 2 cups of milk, 4 cups of flour, and 8 cups of broth. This makes sense because 8 cups of broth is four times as many as 2 cups of milk, and 4 cups of flour is double 2 cups of milk.

- b. Support your answer with equations.

Let x represent the number of cups of milk used in the recipe. $2x$ represents the number of cups of flour, and $4x$ represents the number of cups of broth. Added together, they equal 14 cups.

$$x + 2x + 4x = 14$$

$$7x = 14$$

$$7x \div 7 = 14 \div 7$$

$$x = 2$$

If $x = 2$, then $2x = 2(2) = 4$, and $4x = 4(2) = 8$.

G6-M4-Lesson 30: One-Step Problems in the Real World

Angles: A Review

Students review the measures of four angles in this lesson. Using the information below, students create and solve one-step equations based on measurements of angles.

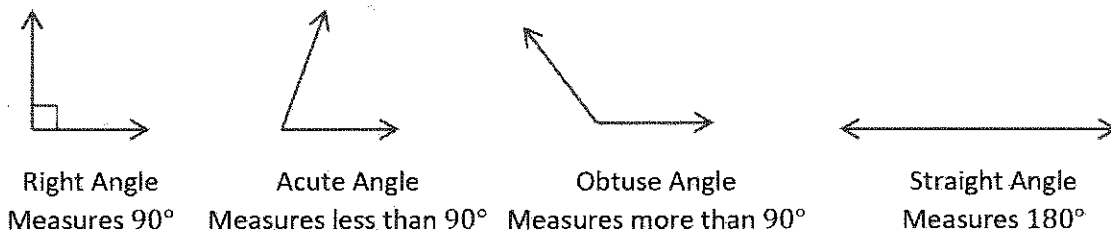

Write and solve equations for each problem.

1. Solve for x .

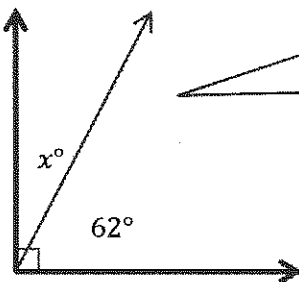

I know a right angle measures 90° . I also know that angle measurements are additive. I know part of the angle measure is 62° , but I don't know the value of x . If I add x° and 62° , it will equal 90° .

$$\begin{aligned}x^\circ + 62^\circ &= 90^\circ \\x^\circ + 62^\circ - 62^\circ &= 90^\circ - 62^\circ \\x^\circ &= 28^\circ\end{aligned}$$

2. Solve for x .

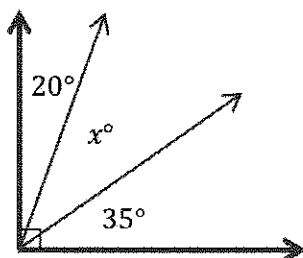

$$\begin{aligned}20^\circ + x^\circ + 35^\circ &= 90^\circ \\x^\circ + 55^\circ &= 90^\circ \\x^\circ + 55^\circ - 55^\circ &= 90^\circ - 55^\circ \\x^\circ &= 35^\circ\end{aligned}$$

I know a right angle measures 90° . I also know that angle measurements are additive. I know part of the angle measure is 20° , and another part is 35° , but I don't know the value of x . If I add x° , 20° , and 35° , it will equal 90° .

3. Solve for x .

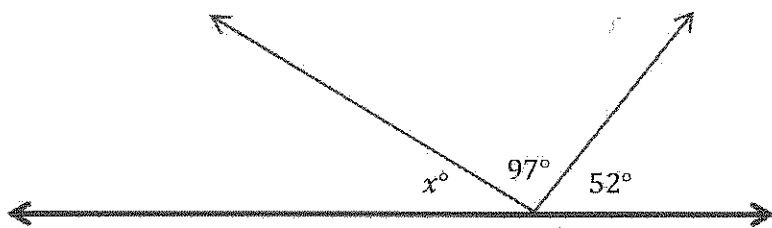

I know a straight angle measures 180° . I also know that angle measurements are additive. I know part of the angle measure is 97° , and another part is 52° , but I don't know the value of x . If I add x° , 97° , and 52° , it will equal 180° .

$$x^\circ + 97^\circ + 52^\circ = 180^\circ$$

$$x^\circ + 149^\circ = 180^\circ$$

$$x^\circ + 149^\circ - 149^\circ = 180^\circ - 149^\circ$$

$$x^\circ = 31^\circ$$

4. The measure of two angles have a sum of 90° . The measures of the angles are in a ratio of 3:2. Determine the measures of both angles.

$$3x^\circ + 2x^\circ = 90^\circ$$

$$5x^\circ = 90^\circ$$

$$5x^\circ \div 5 = 90^\circ \div 5$$

$$x^\circ = 18^\circ$$

I know the ratio of the two unknown angles is 3:2. This means there is a multiplicative comparison. The first angle is three times as many, and the second angle is two times as many. I can find the unknown angles by adding the three times as many, $3x$, and the two times as many, $2x$. Since angle measurements are additive, $3x^\circ + 2x^\circ$ is equal to 90° .

If one x is 18° , then two x 's is 36° , and three x 's is 54° . Since the ratio of the angles is 3:2, then the angles measure 54° and 36° .

G6-M4-Lesson 31: Problems in Mathematical Terms

1. Barbara buys four books every month as part of a book club. To determine the number of books she can purchase in any given number of months, she uses the equation $b = 4m$, where b is the total number of books bought and m is the number of months. Name the independent variable and dependent variable. Create a table to show how many books she buys in less than 6 months.

The independent variable is m , or the number of months. The dependent variable, b , represents the number of books, and that depends on the number of months.

The independent variable is represented in the first column. I know that the number of months will change because the problem states *less than 6 months*. So, the number of months could be 1–5. Therefore, m , or the number of months, is the independent variable.

Number of Months (m)	Evaluating the Expression $b = 4m$	Total Number of Books (b)
1	$b = 4m$ $b = 4(1)$ $b = 4$	4
2	$b = 4m$ $b = 4(2)$ $b = 8$	8

The dependent variable is represented in the third column. The total number of books, b , depends on the number of months, so b is the dependent variable.

To determine the value of b , I replace m by the number of months it represents and then evaluate the expression.

Number of Months (m)	Total Amount of Books (b)
1	4
2	8
3	12
4	16
5	20

2. Tamara was given ten stamps. Each week, she collects three more stamps. Let w represent the number of weeks Tamara collects stamps and s represent the total number of stamps she has collected. Which variable is independent, and which is dependent? Write an equation to model the relationship, and make a table to show how many stamps she has from weeks 5–10.

$s = 3w + 10$. The total number of stamps collected, s , is the dependent variable because it depends on the number of weeks Tamara collects stamps. The independent variable is the number of weeks Tamara collects stamps, w . 10 is a constant.

The independent variable is represented in the first column. I know that the number of weeks will change because the problem states *from weeks 5–10*. Therefore, w , or the number of weeks, is the independent variable.

Number of Weeks(w)	Total Number of Stamps (s)
5	25
6	28
7	31
8	34
9	37
10	40

To determine the value of s , I replace w by the number of weeks it represents and then evaluate the equation.

$$s = 3w + 10$$

$$s = 3(5) + 10$$

$$s = 15 + 10$$

$$s = 25$$

I need to do this for all values of w .

G6-M4-Lesson 32: Multi-Step Problems in the Real World

Beverly started saving money in a new account. She opened her account with \$50. She adds \$20 every week. Write an equation where w represents the number of weeks and t represents the total amount of money in the account, assuming no money is taken out and no interest is accrued. Determine which variable is independent and which is dependent. Then graph the total amount in the account for w being less than 8 weeks.

$$t = 20w + 50$$

To determine the amount of money Beverly saves, I need to multiply the number of weeks by the amount of money she saves each week: $20w$. Then I need to add the original \$50 to that product: $20w + 50$.

t is the dependent variable.

w is the independent variable.

I know that the number of weeks, w , is the independent variable. I am given those values: 0–7. I know that w will be measured along the x -axis. The total amount of money, t , depends on how many weeks Beverly saves. I know that t is the dependent variable and will be measured along the y -axis.

The independent variable is measured along the x -axis.

The dependent variable is measured along the y -axis.

Independent Variable (w)	Solving the Equation	Dependent Variable (t)	Ordered Pair (x, y)
0	$t = 20w + 50$ $t = 20(0) + 50$ $t = 0 + 50$ $t = 50$	50	(0, 50)
1	$t = 20w + 50$ $t = 20(1) + 50$ $t = 20 + 50$ $t = 70$	70	(1, 70)
2	$t = 20w + 50$ $t = 20(2) + 50$ $t = 40 + 50$ $t = 90$	90	(2, 90)

I know the amount of weeks because the problem says *less than 8 weeks*. This includes 0–7.

I use the equation $t = 20w + 50$ to determine values for t . I substitute the value for w and evaluate the expression.

I can create ordered pairs to plot on a graph using the values for the independent and dependent values.

Number of Weeks (w)	Total Amount of Money in Dollars (t)
0	50
1	70
2	90
3	110
4	130
5	150
6	170
7	190

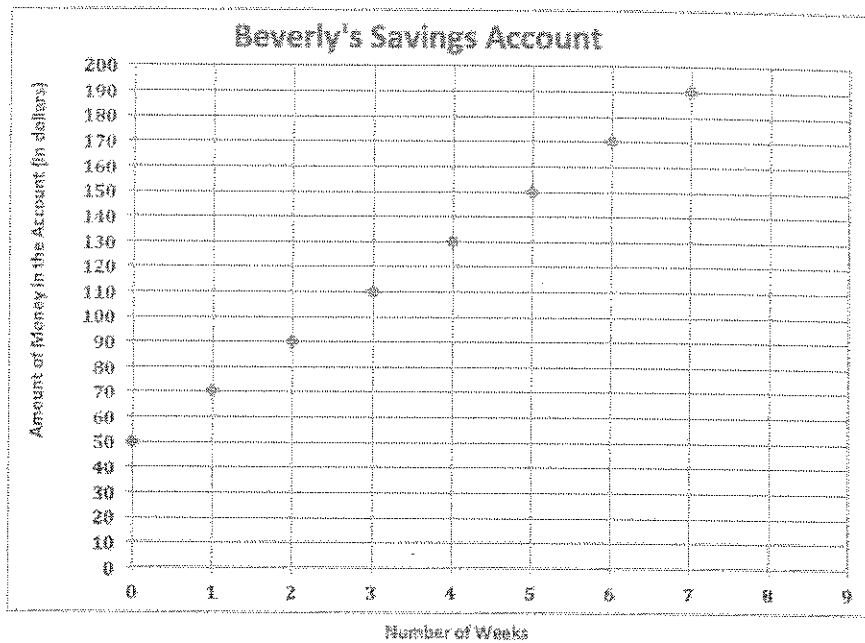

A point is placed at the intersection of the (x, y) coordinates. Beginning at zero, I move horizontally along the x -axis first to the first x -value and then vertically along the y -axis to the first y -value. There I place a point. I continue to do this for each of the ordered pairs created from the table to the left.

G6-M4-Lesson 33: From Equations to Inequalities

Moving from Equations to Inequalities

Students move from naming the values that make the sentence true or false to using a set of numbers and determining whether or not the numbers in the set make the equation or inequality true or false.

Choose the numbers that make the equation or inequality true from the following set of numbers: $\{2, 4, 6, 8, 9, 17\}$

1. $m - 2 = 6$

 $\{8\}$

8 is the only number that makes this equation true.

$$\begin{aligned}m - 2 + 2 &= 6 + 2 \\m &= 8\end{aligned}$$

2. $m - 2 < 6$

 $\{2, 4, 6\}$

$$\begin{aligned}m - 2 + 2 &< 6 + 2 \\m &< 8\end{aligned}$$

Because the number that m represents has to be less than 8, the only numbers from the set that are less than 8 are 2, 4, and 6.

3. $3x = 27$

 $\{9\}$

9 is the only number that makes this equation true.

$$\begin{aligned}3x \div 3 &= 27 \div 3 \\x &= 9\end{aligned}$$

4. $3x \geq 27$

 $\{9, 17\}$

$$\begin{aligned}3x \div 3 &\geq 27 \div 3 \\x &\geq 9\end{aligned}$$

Because the number that x represents has to be greater than or equal to 9, the only numbers from the set that are greater than or equal to 9 are 9 and 17.

5. $\frac{1}{5}h = 6$

There is no number in the set that makes this equation true.

$$\begin{aligned}\frac{1}{5}h \cdot 5 &= 6 \cdot 5 \\ h &= 30\end{aligned}$$

Because the number that h represents has to be equal to 30, and none of the number choices from the set are 30, then there is no number in the set that makes this equation true.

G6-M4-Lesson 34: Writing and Graphing Inequalities in Real-World Problems

Graphing Inequalities

When an inequality has a variable that is less than or equal to or greater than or equal to (\leq or \geq) a number, then (because the solution includes the number) the point is plotted on the graph. For example: $x \leq 9$ (x is less than or equal to 9). This solution will include 9 and all numbers less than 9. To plot 9 on the graph, it is represented with a closed circle because it is a solution to the inequality. A ray to the left of 9 represents all rational numbers less than 9 because they are all solutions to the inequality.

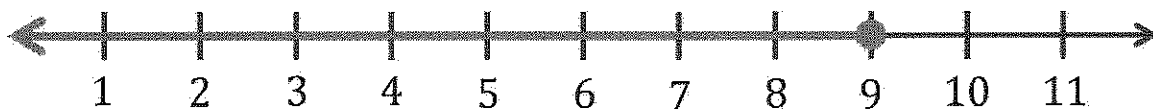

When an inequality is less than or greater than a number ($<$ or $>$), the solution does not include the number. The number is the beginning place, and instead of plotting a closed point on the graph, an open point (or open circle) determines the beginning place. For example: $x > 9$ (x is greater than 9). An open point at 9 is plotted on the graph since 9 is not a solution to the inequality but a beginning point. A ray to the right of 9 represents all rational numbers greater than 9 because they are all solutions to the inequality.



Write and graph an inequality for each problem.

1. At least 64
 $x \geq 64$

I know numbers that are *at least* 64 include 64 as the least amount and any number greater than 64. I need to plot 64 with a point and all numbers greater than 64 with a ray to the right of 64.



2. Less than 10

$x < 10$

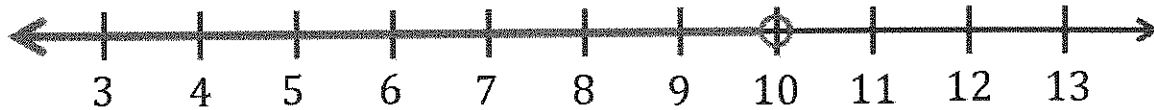

I know numbers that are *less than* 10 do not include 10, but I should start with 10 as a beginning point. I need to plot an open point (or circle) at 10 and represent all numbers less than 10 with a ray to the left of 10.

3. Cameron needs at least 10 minutes to finish his assignment. However, he must finish in under 30 minutes.

$10 \leq x < 30$

I know numbers that are *at least* 10 include 10 as the least amount. I should start with 10 as a beginning point. If Cameron needs to finish *under* 30 minutes, 30 is my stopping point. The solution set does not include 30 because *under* 30 is *less than* 30.

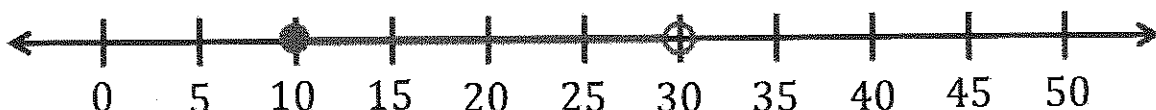

All numbers between 10 (including 10) and 30 (not including 30) need to be represented. I need to plot a point at 10 and represent all numbers greater than 10 with a line segment to the right of 10 until I reach 30. My stopping point is 30, which I will represent with an open point, or an open circle.